

ICC-ES Evaluation Report

ESR-1774

Reissued August 1, 2009

This report is subject to re-examination in one year.

www.icc-es.org | (800) 423-6587 | (562) 699-0543

A Subsidiary of the International Code Council®

DIVISION: 06—WOOD AND PLASTICS
Section: 06170—Prefabricated Structural Wood

REPORT HOLDER:

REDBUILT™ LLC
200 EAST MALLARD DRIVE
BOISE, IDAHO 83706
(866) 859-6757
www.redbuilt.com

EVALUATION SUBJECT:
OPEN-WEB TRUSSES
1.0 EVALUATION SCOPE
Compliance with the following codes:

- 2006 *International Building Code*® (IBC)
- 2006 *International Residential Code*® (IRC)
- BOCA® *National Building Code/1999* (BNBC)
- 1999 *Standard Building Code*® (SBC)
- 1997 *Uniform Building Code*™ (UBC)

Properties evaluated:

- Structural
- Sound ratings
- Fire-resistance ratings

2.0 USES

The Open-Web trusses described in this report are used as floor joists or roof rafters.

3.0 DESCRIPTION
3.1 General:

Open-Web trusses are Warren-style trusses that have either parallel, tapered or pitched chord members. The trusses have sawn lumber or engineered wood chords, steel-tube webs, and solid-steel pins used as web-chord connectors. Open-Web trusses recognized in this evaluation report are designated Red-L™, Red-W™, Red-S™, Red-M™, and Red-H™. These products may also be trademarked as TJL™, TJW™, TJS™, TJM™, and TJH™, respectively. Sheathing materials are nailed directly to the top chord members. Ceilings are either attached directly to the bottom chord, applied to stripping or resilient (or hat) channels attached to the bottom chord, or are suspended from the bottom chord.

3.2 Red-L Open-Web Truss:

Chords are single nominally 2-by-4 MSR (machine stress rated) lumber, or 1.5-inch-by-3.5-inch (38 mm by 89 mm) LVL or LSL positioned flatwise. Web members are round steel tubing connected to the chord members with either $\frac{3}{8}$ -inch- or $\frac{5}{8}$ -inch-diameter (9.5 mm or 15.9 mm) solid-steel pins.

3.3 Red-W Open-Web Truss:

Chords are single 1.5-inch-by-4.75-inch (38 mm by 121 mm) MSR lumber or LSL positioned flatwise. Web members are round steel tubing connected to chord members with either $\frac{3}{8}$ -inch- or $\frac{5}{8}$ -inch-diameter (9.5 mm or 15.9 mm) solid-steel pins.

3.4 Red-S Open-Web Truss:

Chords are double 1.5-inch-by-2.3-inch (38 mm by 58 mm) LVL members positioned edgewise. Web members are round steel tubing connected to chord members with either $\frac{1}{2}$ -inch- or $\frac{3}{4}$ -inch-diameter (12.7 mm or 19.1 mm) solid-steel headed pins. The pins are held in place by spring-clip washers placed on the end of the pins. Tension chords are continuous without finger joints, and compression chords may contain finger joints.

3.5 Red-M Open-Web Truss:

Chords are double nominally 2-by-4 MSR lumber or 1.5-inch-by-3.5-inch (38 mm by 89 mm) LVL positioned edgewise. Web members are round steel tubing connected to chord members with either $\frac{5}{8}$ -inch- or 1-inch-diameter (15.9 mm or 25.4 mm) solid-steel headed pins. The pins are held in place by spring-clip washers placed on the end of the pins.

3.6 Red-H Open-Web Truss:

Chords are double nominally 2-by-6 MSR lumber or 1.5-inch-by-5.5-inch (38 mm by 140 mm) LVL positioned edgewise. Web members are round steel tubing connected to the chord members with either $\frac{3}{4}$ -inch- or $1\frac{1}{4}$ -inch-diameter (19.1 mm or 31.8 mm) solid-steel headed pins. The pins are held in place by spring-clip washers placed on the end of the pins.

3.7 Materials:

3.7.1 Chords: Chords consist of either Redlam LVL, Microllam LVL, TimberStrand LSL, or MSR lumber. Redlam LVL is recognized in [ESR-2993](#). Microllam LVL and TimberStrand LSL are recognized in [ESR-1387](#). MSR lumber is graded as either 2100F-1.8E, 2400F-2.0E, or 2700F-2.2E in accordance with grading rules specified in the approved quality control manual that includes the RedBuilt manufacturing standards. Lumber species are

Douglas fir–larch, southern pine, hem-fir, spruce-pine-fir, or Englemann spruce/lodgepole pine.

Chords having glued finger joints are manufactured and tension-tested in accordance with the approved quality control manual that includes the RedBuilt manufacturing standards, to form continuous chord members.

3.7.2 Webs: Webs are cold-formed steel tubes conforming to ASTM A 500, Grade B, with the exceptions noted in the RedBuilt Open-Web Truss manufacturing standard. The electrically welded steel tubing ends are swaged flat, and have punched holes for the pin connectors. Each web member gage is identified as specified in the RedBuilt Open-Web truss manufacturing standard.

3.7.3 Pin Connectors: The steel pin connectors are of the dimensions and materials as specified in the approved RedBuilt Open-Web truss quality control manual and manufacturing standard.

3.7.4 Bearing Clips: Bearing clips have configurations specific to each Open-Web truss series and are fabricated from either ASTM A 36 or ASTM A 653 steel, as specified in the manufacturing standard. See Figure 3 for details.

3.7.5 Tension Connector: The tension connector is a variable-density LVL component used at splice locations of the truss tension chords. The tension connector has both nondensified and densified sections. The nondensified section is finger-jointed to sawn lumber tension chord members, and the densified section is spliced with steel plates on both sides of the connector with the number of bolts required by design. See Figure 2 for details.

4.0 DESIGN AND INSTALLATION

4.1 General:

The design and installation of the Open-Web trusses described in this report must comply with Sections 4.1 through 4.15 of this report and must be governed by the applicable code, the ANSI/AF&PA National Design Specification for Wood Construction (NDS) and accepted truss design principles.

4.2 Chord Members:

Table 1 provides chord section properties and Table 2 provides allowable chord stresses. The top chords of the Open-Web trusses are designed as continuous members subject to combined axial and bending stresses. The bottom chords are designed as axially loaded tension members, provided ceilings that are directly applied to the chords, or stripping spaced not more than 24 inches (610 mm) on center, do not weigh more than 5 psf (0.24 kN/m²). For other conditions, the bottom chords are designed as continuous members subject to combined axial tension and bending stresses.

4.3 Web Members:

Table 3 provides maximum allowable axial tension and compression loads for web members, including bearing on the steel pins. The allowable load values for web members in compression must be further limited when long column buckling controls, as determined by analysis in accordance with the AISI-NASPEC 2001, including the 2004 Supplement.

4.4 Pin Connectors:

Table 4 provides allowable loads for pin connectors bearing on chord members. The allowable load for the resultant parallel and perpendicular pin loading on the chord member must be determined using the Hankinson formula in accordance with the applicable code.

4.5 Bearing Assemblies:

Tables 5 and 6 provide allowable reactions at supports with bearing clips. See Figure 3.

4.6 Duration of Load:

Increases for duration of load, as provided for wood members and their connections, shall be in accordance with the limitations specified in the applicable code and as set forth in this report, unless specifically prohibited by this report.

4.7 Repetitive Member Use:

When Open-Web truss installation complies with repetitive-member use in accordance with Part 4.3.9 of the NDS, the allowable parallel-to-grain tension and compression chord stresses noted in Table 2 and the allowable pin bearing loads on chord members noted in Table 4 may be increased by 7 percent for sawn lumber and by 4 percent for Redlam LVL or TimberStrand LSL chords.

4.8 Deflection:

For uniformly loaded simple-span applications, maximum deflection, in inches, is calculated as follows:

$$\Delta = \frac{22.5WL^4}{EI}$$

where:

EI = Truss stiffness in the table below (lb.-in.²).

OPEN-WEB TRUSS SERIES	CHORD DEPTH (inches)	EI (lb.-in. ²)
Red-L	1.5	$5.0 \times 10^6 d^2$
Red-LX	1.5	$5.26 \times 10^6 d^2$
Red-W	1.5	$6.78 \times 10^6 d^2$
Red-S	2.3	$6.94 \times 10^6 d^2$
Red-M	3.5	$10.06 \times 10^6 d^2$
Red-H	5.5	$15.93 \times 10^6 d^2$

For SI : 1 lb.-in.² = 2870 N-mm², 1 in = 25.4 mm.

d = Average depth of the truss minus the chord depth in the table above (pin-to-pin depth of the truss) (inches).

W = Uniform load (plf).

L = Clear span (feet).

4.9 Tension Connector:

The variable-density LVL tension-connector design parameters are as follows:

Bolt bearing in wood: 6,800 psi (46.88 MPa).

Tension in densified net area: 2,700 psi (18.62 MPa).

Tension in nondensified area: 1,970 psi (13.58 MPa).

The bolt end distance (e), measured from the center of the bolt to the end of the member, must not be less than $4d$ or e_{min} , whichever is greater, where;

d = Diameter of bolt (inches).

$e_{min} = P \div (1,200t)$

P = Load per bolt (pounds).

t = Thickness of connector, measured along the bolt (inches).

Steel side plates and bolts must be designed in accordance with the code.

4.10 Lateral Support:

Each Open-Web truss compression chord member, including each member of double member chords, requires lateral support at least every 24 inches (610 mm). Each connection must be capable of transmitting a minimum allowable lateral load of 75 pounds (334 N). Table 7 provides lateral restraint requirements for Open-Web truss compression chord members.

4.11 Metal Strap or Tension-tie Capacity:

The allowable capacities for metal straps or tension-ties, recognized in a current ICC-ES evaluation report, when connected to structural composite lumber chord members or minimum nominally 2-by-4 structural composite lumber nailer plates of Open-Web trusses, in conformance with Figure 6 of this report, may be calculated using an allowable stress design capacity of 112 pounds (498 N) per nail. The connections with the structural composite lumber chords or nailer plates may be used for out-of-plane wall anchorage to flexible diaphragms in lieu of the minimum 2¹/₂-inch (63.5 mm) wood element thickness specified in Item 5 of Section 1633.2.8.1 of the UBC.

4.12 One-hour Fire-resistance-rated Roof-ceiling or Floor-ceiling Assemblies:

Refer to Figure 4 for details. For assemblies A, B, C, D, and E used as floor-ceiling assemblies over crawl spaces, the ceiling membrane may be omitted over the unusable crawl space. Additionally, flooring may be omitted where unusable attic space occurs above, provided the lateral support requirements of Section 4.10 are met.

4.12.1 Assembly A:

1. A double wood floor consisting of a subfloor of nominally 1-inch-thick (25.4 mm) tongue-and-groove sheathing or 32/16 span-rated, wood-based, structural-use sheathing (Exposure 1); and a second layer of nominally 1-inch-thick (25.4 mm), tongue-and-groove finish sawn lumber flooring. Alternatively, the finish flooring may be 40/20 span-rated wood-based structural-use sheathing (Exposure 1).

All butt joints of the sheathing must be located over framing members.

When use is as a roof-ceiling assembly, a single layer of square-edge span-rated wood-based structural-use sheathing (Exposure 1), complying with the code, may be used for roof sheathing.

2. Open-Web trusses must be installed in accordance with this report, at a maximum spacing of 48 inches (1219 mm) on center.
3. A suspended ceiling consists of 5/8-inch-thick (15.9 mm), 2-foot-by-2-foot (610 mm by 610 mm) or 2-foot-by-4-foot (610 mm by 1219 mm), USG FIRECODE AURATONE lay-in acoustical board supported by an approved, fire-resistance-rated suspension system, attached to the bottom chord or to cold-rolled steel channels spaced not more than 48 inches (1219 mm) on center. Connection and anchorage of the suspended ceiling to the trusses must comply with Section 803.9 of the IBC and, when applicable, Section 13.5.6 of ASCE 7. When Open-Web trusses are spaced more than 24 inches (610 mm) on center, framing perpendicular to the trusses must be installed at 24 inches (610 mm) on center to support the ceiling. The distance from the bottom of the Open-Web truss to the suspended ceiling must be a minimum of 10 inches (254 mm).

4. Installed over the acoustical board are minimum 1-inch-thick (25.4 mm), 4 pcf (64 kg/m³), Thermafiber[®] Sound Attenuation Fire Blanket, Fibrex[®]-FBX 1240 Industrial Boards, Fibrex[®]-IF 1240 Flex Batts, IIG MinWool[®]-1240 Industrial Board, or IIG MinWool[®]-1240 Flexible Batt.
5. Light fixtures having a maximum size of 2 feet by 4 feet (610 mm by 1219 mm) may be installed in the ceiling, provided the aggregate area of fixtures does not exceed 12 square feet per 100 square feet (1.1 m² per 9.3 m²) of ceiling area and the fixtures are protected as follows [using, for illustration, a 2-foot-by-4-foot (610 mm by 1219 mm) fixture]: A 2¹/₄-inch-by-48 inch (57 mm by 1219 mm), minimum 1¹/₄-inch-thick (31.8 mm) piece of minimum 4 pcf (64 kg/m³) Thermafiber rigid mineral fiber board or Fibrex-FBX 1240 Industrial Board or Fibrex-IF 1240 Flex Batt light fixture protection is laid along the long sides of the fixture, and against adjacent suspension members; two pieces of the same insulation, measuring 19¹/₂ inches by 48 inches (495 mm by 1219 mm), are laid over the top of the fixture and a 4¹/₂-inch-by-24-inch (114 mm by 610 mm) piece of the same insulation is laid at each end and tied at the corners of the fixture, to the top pieces, using No. 18 SWG steel wire. See Figure 1 for details. In addition, ceiling openings for air diffusers, up to a maximum of 12 inches (305 mm) in diameter, are permitted, provided openings are protected with approved fire dampers and the aggregate areas do not exceed 113 square inches (72 900 mm²) per 100 square feet (9.3 m²) of ceiling area.

4.12.2 Assembly B:

1. The flooring must consist of a single layer of 48/24 span-rated, tongue-and-groove, wood-based structural-use sheathing (Exposure 1). When use is as a roof-ceiling assembly, the roof sheathing may be any wood sheathing material permitted by the code. All butt joints of the sheathing must be located over framing members.
2. Open-Web trusses must be installed in accordance with this report, with a maximum spacing of 24 inches (610 mm) on center for floor-ceiling assemblies. When used in roof-ceiling assemblies, the trusses may be spaced a maximum of 48 inches (1219 mm) on center.
3. Optional minimum 3¹/₂-inch-thick (89 mm) glass fiber insulation, rated R-30 or less, may be installed in the truss plenum when resilient channels are used. The insulation must be placed above the resilient channels between the truss bottom chords.
4. The ceiling membrane must consist of two layers of 1/2-inch-thick (12.7 mm), Type X gypsum board complying with ASTM C 36 or ASTM C 1396, attached to the truss bottom chord.

The first layer of gypsum board must be attached using 1⁵/₈-inch-long (41.3 mm), Type S screws spaced 12 inches (305 mm) on center. The second layer must be installed with the joints staggered from the first layer, and fastened to the trusses with 2-inch-long (51 mm), Type S screws spaced 12 inches (305 mm) on center in the field and 8 inches (203 mm) on center at the butt joints.

Type G screws, 1¹/₂ inches (38 mm) long, must be spaced 8 inches (203 mm) on center and 6 inches (152 mm) from each side of the butt joints of the

second layer. The second layer must be finished with joint tape and compound.

- Resilient channels may be used as part of the ceiling attachment system, provided they are spaced 16 inches (406 mm) on center [24 inches (610 mm) on center if the trusses are spaced 16 inches (406 mm) on center] and fastened perpendicular to the trusses using 1-inch-long (25.4 mm), Type S screws. The first layer of the ceiling membrane must be attached to the resilient channels using 1-inch-long (25.4 mm), Type S screws spaced 12 inches (305 mm) on center. The second layer must be installed with the joints staggered from the first layer and must be attached using 1⁵/₈-inch-long (41.3 mm), Type S screws. The screw spacing for the second layer of gypsum board must not exceed 12 inches (305 mm) on center in the field and 8 inches (203 mm) on center at the butt joints.

Type G screws, 1¹/₂ inches (38 mm) long, must be spaced 8 inches (203 mm) on center and 6 inches (152 mm) from each side of the butt joints of the second layer. The second layer must be finished with joint tape and compound.

In roof-ceiling assemblies in which the Open-Web trusses are spaced more than 24 inches (610 mm) on center, the ceiling, including the resilient channels, must be applied to stripping spaced 24 inches (610 mm) on center. The attachment of the ceiling membrane to the stripping members must be similar to the attachment of the ceiling membrane to the trusses. The stripping must be a minimum of nominally 2-by-4 construction-grade Douglas fir lumber for spans up to 5 feet (1524 mm), and must be attached to the bottom chord using a minimum of two 10d box nails. Stripping materials of equivalent strength and attachment are permitted when specifically approved by the code official.

4.12.3 Assembly C:

- The flooring must consist of a single layer of 48/24 span-rated, tongue-and-groove, wood-based, structural-use sheathing (Exposure 1). When use is as a roof-ceiling assembly, a single layer of square-edge, span-rated, wood-based structural-use sheathing (Exposure 1), complying with the code, may be used for roof sheathing. All butt joints of the sheathing must be located over framing members.
- Open-Web trusses must be installed in accordance with this report, with a maximum spacing of 24 inches (610 mm) on center for floor-ceiling assemblies. When used in roof-ceiling assemblies the trusses may be spaced a maximum of 48 inches (1219 mm) on center. When the truss spacing exceeds 24 inches (610 mm) on center, framing perpendicular to the trusses must be installed at 24 inches (610 mm) on center to support the ceiling.
- The ceiling membrane must consist of a single layer of 1/2-inch-thick (12.7 mm), Type X gypsum board complying with ASTM C 36 or ASTM C 1396, attached to the trusses, or to stripping spaced 24 inches (610 mm) on center. The gypsum board must be fastened using 1⁵/₈-inch-long (41.3 mm), Type S screws located 6 inches (152 mm) on center at end joints and 8 inches (203 mm) on center in the field.
- An approved, fire-resistance-rated, suspended-ceiling system must be installed beneath the gypsum board ceiling membrane. The minimum distance between

the suspended ceiling and the gypsum board ceiling membrane must be 12 inches (305 mm). Connection and anchorage of the suspended ceiling to the trusses must comply with Section 803.9 of the IBC and, when applicable, Section 13.5.6 of ASCE 7. The grid system must be suspended with No. 12 SWG galvanized steel wire fastened to the stripping or trusses using 3-inch-long (76 mm) flathead hanger screws. Light fixture protection must consist of 6-inch-wide (152 mm) pieces of ceiling grid panels that are 48 inches (1219 mm) long for the sides, and 24 inches (610 mm) long for the ends, with a full grid panel placed on top.

A galvanized steel duct is permitted for each 200 square feet (18.6 m²) of ceiling, provided the duct has a maximum 12-inch-diameter (305 mm) steel diffuser opening without a damper, and a maximum 6-inch-by-12-inch (152 mm by 305 mm) return air opening. Ceiling panels must be 5/8-inch-thick (15.9 mm) USG FIRECODE AURATONE. Glass fiber insulation that is rated R-30 or less may be installed above the gypsum board, in the cavity between the trusses.

4.12.4 Assembly D:

- The flooring must consist of a single layer of 48/24 span rated, tongue-and-groove, wood-based, structural-use sheathing (Exposure 1). When use is as a roof-ceiling assembly, a single layer of square-edge, span-rated, wood-based, structural-use sheathing (Exposure 1), complying with the code, may be used for roof sheathing. All butt joints of the sheathing must be located over framing members.
- The Open-Web trusses must be installed in accordance with this report, with a maximum spacing of 24 inches (610 mm) on center.
- The ceiling membrane must consist of a single layer of 1/2-inch-thick (12.7 mm) USG FIRECODE[®] Type C gypsum board or ProRoc[®] Type C gypsum board screw-attached to steel furring channels placed perpendicular to the trusses. The gypsum board side joints must be offset 8 inches (203 mm) from the truss centerlines and fastened to the furring channels with 1-inch-long (25.4 mm) Type S screws located at 3/4 inch and 6 inches (19 mm and 152 mm) from each gypsum board side joint and spaced at 12 inches (305 mm) in the field. The furring channels must be spaced 24 inches (610 mm) on center and must be attached and suspended from the trusses using 24 gage Simpson Strong-Tie CSC Support Clips. A CSC support clip must be located at each truss to support the furring channel. At channel splices, adjacent pieces are overlapped a minimum of 6 inches (152 mm), and are tied with double-strand No. 18 SWG galvanized steel wire at each end of the overlap.
- A layer of 1-inch-thick (25.4 mm), minimum 6 pcf (96 kg/m³), Thermafiber Type CW 90 mineral-wool blanket, Fibrex-FBX 1280 Industrial Board, Fibrex-IF 1280 Flex Batt, IIG MinWool 1260 Industrial Board or IIG MinWool 1260 Flexible Batt, must be placed below the bottom chords of the trusses and on top of the furring channels. Alternatively, a layer of 2-inch-thick (51 mm), Thermafiber mineral-wool blanket, having a density of 8 pcf (128 kg/m³), may be used.

4.12.5 Assembly E:

- The flooring must consist of a double wood floor as described in Section 4.12.1 (Assembly A), or a single layer of 48/24 span-rated, tongue-and-groove, wood-

based, structural-use sheathing (Exposure 1). When trusses are used in a roof-ceiling assembly, a single layer of square-edge, span-rated, wood-based, structural-use sheathing (Exposure 1), complying with the code, may be used for roof sheathing. All butt joints of the sheathing must be located over framing members.

- Open-Web trusses must be installed in accordance with this report, with a maximum spacing of 24 inches (610 mm) on center for floor-ceiling assemblies, and a maximum spacing of 48 inches (1219 mm) on center for roof-ceiling assemblies. When the flooring consists of a double wood floor as described in Section 4.12.1 (Assembly A), the trusses may be spaced a maximum of 48 inches (1219 mm) on center.

When the trusses are spaced more than 24 inches (610 mm) on center, the ceiling, including the resilient channels, must be applied to stripping spaced 24 inches (610 mm) on center. The attachment of the ceiling membrane to the stripping must be similar to the attachment of the ceiling membrane to the trusses. The stripping must be nominally 2-by-4 construction-grade Douglas fir lumber for spans up to 5 feet (1524 mm), and must be attached to the truss bottom chord using a minimum of two 10d box nails. Stripping materials of equivalent strength and attachment are permitted when specifically approved by the code official.

- An approved ceiling membrane having a minimum 40-minute finish rating, as determined in accordance with Sections 45 through 49 of ASTM E 119, must be used, such as two layers of $\frac{1}{2}$ -inch-thick (12.7 mm), Type X gypsum board complying with ASTM C 36 or ASTM C 1396, a minimum of 4 feet (1219 mm) wide, installed perpendicular to the trusses, as described in Section 4.12.2 (Assembly B). Substantiating data, including a report of the fire-endurance testing conducted in accordance with ASTM E 119 or UBC Standard 7-1 must be furnished to the local code official, and must verify that the specified ceiling system meets the 40-minute finish rating requirements.

4.13 Assembly G: Two-hour Fire-resistance-rated Roof-ceiling or Floor-ceiling Assembly:

See Figure 5 for details. When use is as a floor-ceiling assembly over crawl spaces, the ceiling membrane may be omitted over the unusable crawl space. Additionally, flooring may be omitted where unusable attic space occurs above the following system, provided the requirements of Section 4.10 are met.

- The floor sheathing must consist of a single layer of 48/24 span-rated, tongue-and-groove, wood-based, structural-use sheathing (Exposure 1). All butt joints of the floor or roof sheathing must be located over framing members.

When Open-Web trusses are used in a roof-ceiling assembly, a single layer of square-edge, span-rated, wood-based, structural-use sheathing (Exposure 1), complying with the code, may be used as roof sheathing.

- Open-Web trusses must be installed in accordance with this report, with a maximum spacing of 24 inches (610 mm) on center. Minimum truss depth is $9\frac{1}{4}$ inches (235 mm).
- (Optional.) When insulation is used, it must consist of glass-fiber insulation with unfaced batts that are 24

inches (610 mm) wide by 48 inches (1219 mm) long by $3\frac{1}{2}$ inches (89 mm) thick. The insulation must be placed in the plenum and supported by stay wires spaced at 12 inches (305 mm) along the truss bottom chord.

- The ceiling membrane must consist of three layers of $\frac{5}{8}$ -inch-thick (15.9 mm) Gold Bond Fire Shield G, Type X, gypsum board. The base layer must be applied perpendicular to the trusses, with end joints staggered, and must be attached directly to the bottom chords using $1\frac{5}{8}$ -inch-long (41.3 mm), Type S screws spaced 12 inches (305 mm) on center along each truss. Resilient steel channels, minimum No. 28 gage [0.016 inch (0.41 mm)], must be applied under the first layer of gypsum board, perpendicular to the trusses and spaced a maximum of 16 inches (406 mm) on center. The channels must be attached to the bottom chord of each truss with $\frac{5}{8}$ -inch-long (41.3 mm), Type S screws. The middle layer of gypsum board must be installed perpendicular to the resilient channels, with end joints staggered, and attached to the resilient channels with 1-inch-long (25.4 mm), Type S screws spaced 12 inches (305 mm) on center. The finish layer of gypsum board must be installed with edges and end joints staggered from the middle layer, and must be fastened to the resilient channels using $1\frac{5}{8}$ -inch-long (41.3 mm), Type S screws spaced 8 inches (203 mm) on center. Joints of the finish layer of gypsum board must be covered with joint compound and paper tape, and exposed screw heads must be covered with joint compound.

4.14 Alternate Floor or Roof Deck Systems for Fire-resistance-rated Assemblies:

An alternate floor or roof deck to Assemblies A, B, C, D, and E, described in Sections 4.12.1 through 4.12.5, respectively, and to the two-hour assembly described in Section 4.13, consists of minimum 48/24 span-rated, wood-based, structural-use sheathing (Exposure 1) over Open-Web trusses spaced a maximum of 24 inches (610 mm) on center, with either $1\frac{1}{2}$ -inch-thick (38 mm) lightweight concrete or $\frac{3}{4}$ -inch-thick (19.1 mm) gypsum concrete over the sheathing. When the trusses are limited to a maximum spacing of 20 inches (508 mm) on center, a minimum 40/20 span-rated, wood-based, structural-use sheathing may be used. The gypsum concrete must be recognized in a current ICC-ES evaluation report, and the report must include an evaluation for fire resistance that permits the replacement of the floor systems with the sheathing and gypsum-concrete system.

4.15 Sound Ratings:

4.15.1 Assembly B, Option 1, STC = 50: Assembly B (described in Section 4.12.2 and shown in Figure 4) has a minimum sound transmission class (STC) rating of 50 when constructed with resilient channels spaced at 16 inches (406 mm) on center to separate the ceiling membrane from the structural framing. This assembly has the following minimum impact insulation class (IIC) ratings when constructed with the corresponding additional materials described below.

- IIC rating of 60: The floor covering must include a 40-ounce-per-square-yard (1.36 kg/m^2) pad and a 56-ounce-per-square-yard (1.90 kg/m^2) carpet.
- IIC rating of 51: The floor covering must consist of Tarkett Acoustiflor sheet vinyl, the ceiling must consist of two layers of $\frac{5}{8}$ -inch-thick (15.9 mm), Type X gypsum board, and the bottom of the floor cavity must contain $3\frac{1}{2}$ -inch-thick (89 mm) glass-fiber insulation.

- IIC rating of 45: The floor covering must include a 43.2-ounce-per-square-yard (1.47/kg/m²), minimum 0.123-inch-thick (3.1 mm) cushioned vinyl.

4.15.2 Assembly B, Option 2, STC = 58: Assembly B (described in Section 4.12.2 and shown in Figure 4) has a minimum STC rating of 58 when constructed with resilient channels spaced at 16 inches (406 mm) on center to separate the ceiling membrane from the structural framing, and with a ³/₄-inch-thick (19.1 mm) floor topping of gypsum concrete recognized in a current evaluation report. This assembly has the following IIC ratings when constructed with the additional materials described below.

- IIC rating of 54: The floor covering must include a 40-ounce-per-square-yard (1.36 kg/m²) pad and a 56-ounce-per-square-yard (1.90 kg/m²) carpet.
- IIC rating of 54: The floor covering must consist of Tarkett Acoustiflor sheet vinyl, the ceiling must consist of two layers of ⁵/₈-inch-thick (15.9 mm) Type X gypsum board, and the bottom of the floor cavity must contain 3¹/₂-inch-thick (89 mm) glass fiber insulation.
- IIC rating of 50: The floor covering must be either Armstrong VIOS or Armstrong Cambray sheet vinyl, the ceiling must consist of two layers of ⁵/₈-inch-thick (15.9 mm), Type X gypsum board, and the bottom of the floor cavity must contain 3¹/₂-inch-thick (89 mm) glass fiber insulation.

4.15.3 Assembly D, Option 1, STC = 47, IIC = 54: Assembly D (described in Section 4.12.4 and shown in Figure 4) has an STC rating of 47. This assembly has an IIC rating of 54 when the floor covering includes a 40-ounce-per-square-yard (1.36 kg/m²) pad and a 56-ounce-per-square-yard (1.90 kg/m²) carpet.

4.15.4 Assembly D, Option 2, STC = 59, IIC = 54: Assembly D (described in Section 4.12.4 and shown in Figure 4) has an STC rating of 59 when the assembly is constructed with a ³/₄-inch-thick (19.1 mm) topping of gypsum concrete recognized in a current evaluation report. This assembly has an IIC rating of 54 when the floor covering includes a 40-ounce-per-square-yard (1.36 kg/m²) pad and a 58-ounce-per-square-yard (1.90 kg/m²) carpet.

5.0 CONDITIONS OF USE

The Open-Web trusses described in this report comply with, or are suitable alternatives to what is specified in, those codes listed in Section 1.0 of this report, subject to the following conditions:

- Drawings and design details verifying compliance with this report must be submitted to the code official for approval. The design must be prepared by a registered design professional where required by the statutes of the jurisdiction in which the project is to be constructed.
- No cutting of Open-Web truss chords is permitted.
- Sound-rated assemblies noted in Sections 4.15.1 and 4.15.2 and Figure 4 of this report, with STC and IIC ratings less than 50, are only applicable in jurisdictions using the IRC, BNBC or SBC.
- Open-Web trusses are produced at the RedBuilt plants located in Chino, California; Hillsboro, Oregon; and Delaware, Ohio; with quality control inspections by PFS Corporation (AA-652).

6.0 EVIDENCE SUBMITTED

- Manufacturer's installation instructions.
- Data in accordance with the ICC-ES Acceptance Criteria for Pin-connected Open-web Trusses with Wood Chords and Tubular Steel Webs (AC306), dated April 2007.
- Reports of fire tests in accordance with ASTM E 119.
- Reports of sound transmission tests in accordance with ASTM E 90, E 413, and E 492.

7.0 IDENTIFICATION

Open-Web Trusses are identified by a stamp indicating the product designation, evaluation report number (ICC ESR-1774), manufacturer's name (RedBuilt™ LLC) or logo (see Figure 7), plant number, production date, and the name or logo (see Figure 7) of the inspection agency (PFS Corporation).

TABLE 1—CHORD SECTION PROPERTIES AT PIN LOCATION OF OPEN-WEB TRUSSES

NOMINAL MEMBER SIZE (inches)	NET DIMENSIONS AT 19 PERCENT MOISTURE (inches)	PIN DIAMETER (inches)	NET AREA COMPRESSION (square inches)	NET AREA TENSION (square inches)	SECTION MODULUS (cubic inches)
Red-L					
One 2x4	1 ¹ / ₂ x 3 ¹ / ₂	³ / ₈	4.87 ¹	3.66 ¹	1.20
One 2x4	1 ¹ / ₂ x 3 ¹ / ₂	⁵ / ₈	3.38 ¹	2.73 ¹	1.09
Red-W					
One 2x5	1 ¹ / ₂ x 4 ³ / ₄	³ / ₈	5.06 ¹	5.06 ¹	1.67
One 2x5	1 ¹ / ₂ x 4 ³ / ₄	⁵ / ₈	3.83 ¹	3.83 ¹	1.56
Red-S					
2 members	1 ¹ / ₂ x 2.30	¹ / ₂	5.40	5.40	2.62
2 members	1 ¹ / ₂ x 2.30	³ / ₄	4.65	4.65	2.56
Red-M					
Two 2x4	1 ¹ / ₂ x 3 ¹ / ₂	⁵ / ₈	10.50	8.62	6.09
Two 2x4	1 ¹ / ₂ x 3 ¹ / ₂	1	10.50	7.50	5.98
Red-H					
Two 2x6	1 ¹ / ₂ x 5 ¹ / ₂	³ / ₄	16.50	14.25	15.09
Two 2x6	1 ¹ / ₂ x 5 ¹ / ₂	1 ¹ / ₄	16.50	12.75	14.95

For SI: 1 inch = 25.4 mm, 1 square inch = 645mm², 1 cubic inch = 16 387 mm³.

¹The net area stated in the table for Red-L and Red-W trusses assumes a rout width large enough to accommodate two web members. When bridging clips are to be accommodated, the net area in compression or tension must be reduced to account for the bridging clip thickness.

TABLE 2—ALLOWABLE CHORD STRESSES (psi)

CHORD MATERIAL	TRUSS PRO-FILE ²	TENSION Red-L			TENSION Red-H, Red-M, Red-S		TENSION Red-W			COMPRESSION PARALLEL TO GRAIN, Red-L, Red-H, Red-M, Red-S		COMPRESSION PARALLEL TO GRAIN, Red-W			EXTREME FIBER IN BENDING	MOE x 10 ⁶
		At PP ¹		O t h e r	At PP ¹	O t h e r	At PP ¹		O t h e r	At PP ¹	O t h e r	At PP ¹		O t h e r		
		3/8" Pin	5/8" Pin				3/8" Pin	5/8" Pin				3/8" Pin	5/8" Pin			
Redlam LVL	All Profiles	2300 ³	2300 ³	2100	2300 ³	2100	NA	NA	NA	3000	2550	NA	NA	NA	3000 ^{4,6}	2.06
2100f 1.8E ⁵	Par & T P	1945 1850	1860 1765	1575 1575	1600 1600	1460 1460	1850 1760	1765 1675	1575 1575	1700 1700	1700 1700	2100 2100	1940 1940	1700 1700	2100 ⁶ 2100 ⁶	1.8
2400f 2.0E ⁵	Par & T P	2250 2140	2150 2045	1925 1925	1925 1925	1650 1650	2140 2035	2040 1940	1925 1925	1925 1925	1925 1925	2430 2430	2245 2245	1925 1925	2400 ⁶ 2400 ⁶	2.0
2700f 2.2E ⁵	Par & T P	2550 2425	2440 2320	2150 2150	2200 2200	1900 1900	2425 2305	2315 2200	2150 2150	2500 2500	2500 2500	2760 2760	2550 2550	2200 2200	2700 ⁶ 2700 ⁶	2.2
Timber-Strand LSL	All Profiles	1610	1610	1610	NA	NA	1610	1610	1610	2090 ⁷	2090 ⁷	2090	2090	2090	2620 ⁸	1.55
		2050	2050	2050	NA	NA	2050	2050	2050	2580 ⁷	2580 ⁷	2580	2580	2580	2910 ⁸	1.7

For SI: 1 inch = 25.4 mm, 1 psi = 0.00689 MPa.

¹Allowable chord stress at PP (panel points) must be used at drilled areas.

²Par = parallel profile; T = tapered profile; P = pitched profile.

³For panel point spacing less than 24 inches on center, tension stress must be reduced to 2100 psi.

⁴3000 psi is established for a 12-inch-deep member. When used on edge values for other depths, must be adjusted by multiplying by (12/d)^{0.136}.

⁵Species used are Douglas fir-larch, southern pine, hem-fir, spruce-pine-fir, and Englemann spruce-lodgepole pine.

⁶Stress shown is for chord material used on edge. When loaded flatwise, F_b may be increased 18 percent

⁷Red-L only.

⁸Value shown is for thicknesses up to 3¹/₂ inches.

TABLE 3—ALLOWABLE LOAD ON WEB MEMBERS (pounds)¹

TUBE DIAMETER (inches)	GAGE	WALL THICKNESS (inch)	LOAD CONDITION	OPEN-WEB TRUSS SERIES										
				Red-L		Red-W		Red-S		Red-M		Red-H		
				³ / ₈ " Dia. Pin	⁵ / ₈ " Dia. Pin	³ / ₈ " Dia. Pin	⁵ / ₈ " Dia. Pin	¹ / ₂ " Dia. Pin	³ / ₄ " Dia. Pin	⁵ / ₈ " Dia. Pin	1" Dia. Pin	³ / ₄ " Dia. Pin	¹ / ₄ " Dia. Pin	
1.0	20	0.035	Tension Bearing ²	900 900	1100 900	—	—	—	—	—	—	—	—	—
1.0	19	0.042	Tension Bearing ²	1325 1325	1670 1670	1325 1325	1670 1670	2080 2080	—	—	—	—	—	—
1.0	18	0.049	Tension Bearing ²	1490 1490	1815 1815	1490 1490	1815 1815	—	—	—	—	—	—	—
1.0	16	0.065	Tension Bearing ²	2260 2260	2635 2635	2260 2260	2635 2635	—	—	—	—	—	—	—
1.0	14	0.083	Tension Bearing ²	—	3880 3880	—	3880 3880	—	—	—	—	—	—	—
1 ¹ / ₈	16	0.065	Tension Bearing ²	2280 2280	2755 2755	2280 2280	2755 2755	—	—	3290 2630	—	—	—	—
1 ¹ / ₈	14	0.083	Tension Bearing ²	—	4175 4175	—	4175 4175	—	—	—	—	—	—	—
1 ¹ / ₈	13	0.095	Tension Bearing ²	—	4260 4260	—	4260 4260	—	—	—	—	—	—	—
1 ¹ / ₄	19	0.042	Tension Bearing ²	—	—	—	—	2080 2080	2600 3120	—	—	—	—	—
1 ¹ / ₄	16	0.065	Tension Bearing ²	—	—	—	—	3215 3215	3900 4825	—	—	—	—	—
1 ¹ / ₄	14	0.083	Tension Bearing ²	—	—	—	—	4110 4110	4855 6160	—	—	—	—	—
1 ³ / ₈	16	0.065	Tension Bearing ²	—	—	—	—	—	—	3290 3290	3740 3290	—	—	—
1 ¹ / ₂	16	0.065	Tension Bearing ²	—	—	—	—	3215 3215	4035 4825	3290 3290	4430 3550	3950 3160	—	—
1 ¹ / ₂	14	0.083	Tension Bearing ²	—	—	—	—	4110 4110	5155 6160	—	5530 4430	—	—	—
1 ¹ / ₂	13	0.095	Tension Bearing ²	—	—	—	—	—	—	—	6240 4990	—	—	—
2.0	16	0.065	Tension Bearing ²	—	—	—	—	—	—	—	—	3950 3950	6325 5060	—
2.0	14	0.083	Tension Bearing ²	—	—	—	—	—	—	—	—	5050 5050	7950 6360	—
2.0	13	0.095	Tension Bearing ²	—	—	—	—	—	—	—	—	5770 5770	9000 7200	—

For SI: 1 inch = 25.4 mm, 1 lb = 4.448 N.

¹Allowable load values for web members in tension and compression must be further reduced when the allowable pin bearing loads on chord members, given in Table 4, control.

²Allowable compression (bearing) load values must not exceed values for long columns, as determined by analysis in accordance with the AISI-NASPEC 2001 and 2004 Supplement.

TABLE 4—ALLOWABLE PIN BEARING LOADS ON CHORD MEMBERS (pounds)¹

CHORD MATERIAL	ANGLE OF LOAD TO GRAIN	OPEN-WEB TRUSS SERIES									
		Red-L		Red-W		Red-S		Red-M		Red-H	
		Pin Diameter (inches)									
		³ / ₈	⁵ / ₈	³ / ₈	⁵ / ₈	¹ / ₂	³ / ₄	⁵ / ₈	1	³ / ₄	¹ / ₄
MSR ²	Perpendicular	800	860	855	1075	NA	NA	970	1300	1080	1620
	Parallel ³	1350	2940	1975	3990	NA	NA	2500	4800	3360	6040
Redlam LVL	Perpendicular	500	500	NA	NA	1130	1130	1560	1695	1795	2315
	Parallel ³	1200	1850	NA	NA	1910	3940	2940	5620	3940	6380
1.55E TimberStrand LSL	Perpendicular	850	850	940	1200	NA	NA	NA	NA	NA	NA
	Parallel ³	980	2300	1100	3120	NA	NA	NA	NA	NA	NA
1.7E TimberStrand LSL	Perpendicular	875	905	1240	1370	NA	NA	NA	NA	NA	NA
	Parallel ³	1825	2940	2060	4145	NA	NA	NA	NA	NA	NA

For SI: 1 inch = 25.4 mm, 1 lb = 4.448 N.

¹Values may be increased for duration of load.

²Values are for Douglas fir-larch, southern pine, hem-fir, spruce-pine-fir and Englemann spruce-lodgepole pine (1.8E or higher).

³Parallel values are valid for end distance of 9 inches or greater for Red-L and Red-W Open-Web trusses and 12 pin diameters or greater for Red-S, Red-M and Red-H trusses.

TABLE 5—ALLOWABLE REACTIONS FOR STANDARD BEARING CLIPS

OPEN-WEB TRUSS SERIES	DETAIL ¹	MAX. REACTION ² (lbs)	BEARING AREA ³ (sq. in.)
Red-L	L-1	2910	7.0
	L-2	2910	7.0
	L-3	3000	6.25
	L-5/2.25 ⁴	3290	8.2
	L-5/3.25 ⁴	3520 ⁵	11.8
	L-5/4.00 ⁴	3665 ⁵	14.5
	L-6	4510	9.7
Red-W	W-1	4300	14.5
	W-2	5880	13.1
Red-S	S-1	5390	16.2
	S-2	5390	13.8
Red-M	M-1	4330	10.4
	M-2	7390	20.3
	M-3	8310	21.9
	M-4	7610	15.8
	M-5	6500	20.6
Red-H	H-1	9200	23.6
	H-2	9200	29.3
	H-3	12470	24.1

For SI: 1 inch = 25.4 mm, 1 square inch = 645 mm², 1 lb = 4.448 N.

¹See Figure 3 for details.

²Maximum reactions are absolute limits and must not be increased. Also see Footnote 3.

³Bearing area shown must be used to determine allowable reactions based on allowable compression perpendicular to grain of the plate.

⁴2.25 inches, 3.25 inches, and 4.00 inches are minimum distances from pin to end of chord.

⁵Where full bearing exists (no bearing error), the maximum allowable bearing reaction may be increased to 3780 pounds and 3930 pounds for the L-5/3.25 and L-5/4.00 clips, respectively.

TABLE 6—ALLOWABLE REACTIONS FOR FLUSH-MOUNT BEARING CLIPS^{1,2,3}

OPEN-WEB TRUSS SERIES	BASED ON ALLOWABLE WOOD BEARING STRESS (psi)			BASED ON ALLOWABLE STEEL BEARING STRESS
	405	555	600	
	Allowable Reaction Load (lbs)			
Red-L	3125	3745	4015	5210
Red-W	3125	3745	4015	5210
Red-S	3995	4835	5220	7310
Red-M	5240	6230	6415	11505
Red-H	6620	8115	8775	12055

For SI: 1 lb = 4.448N, 1 psi = 0.00689 MPa.

¹A maximum overhang of 1/4 inch is allowed for all flush-mount bearing clips at published design loads.

²For flush-mount bearing clip details, refer to Figure 3.

³The connection strength of the flush-mount bearing clip to the truss chord, in tension and compression, along the top chord axis to resist seismic or wind forces is as follows (the connection strength between the flush-mount bearing clip and the bearing support must be designed):

OPEN-WEB TRUSS SERIES	ALLOWABLE AXIAL TENSION OR COMPRESSION CAPACITY AT 133% DURATION OF LOAD (lbs)	
	Single Pin	Double Pin Extension
	Red-L	2705
Red-W	3700	6115
Red-S (with or without top chord nailer)	4320	8125
Red-M (with or without top chord nailer)	5115	10235
Red-H (with or without top chord nailer)	6325	12220

For SI: 1 lb = 4.448 N.

TABLE 7—OPEN-WEB TRUSS SHEATHING NAILING PATTERN

NAIL SIZE		WIRE DIAMETER (inches)	CLOSEST ALLOWABLE NAIL SPACING (inches)				
			Red-L and Red-W			Red-S	Red-M Red-H
			Sawn Lumber Chord	Redlam LVL Chord	TimberStrand LSL Chord		
8d (2 1/2 in.)	Box	0.113	4	2	1 1/2	4	2
	Common	0.131	6	2	1 1/2	6	2
10d (3 in.)	Box	0.128	6	2	1 1/2	6	2
	Common	0.148	6	3	1 1/2	6	2 1/2
12d (3 1/4 in.)	Box	0.128	6	2	1 1/2	6	2
	Common	0.148	6	3	1 1/2	6	2 1/2
16d (3 1/2 in.)	Box	0.135	6	3	1 1/2	6	2 1/2
	Common	0.162	8	4	1 3/4	8	4

For SI: 1 inch = 25.4 mm.

If more than one row is used, the rows must be offset at least 3/8 inch and staggered.

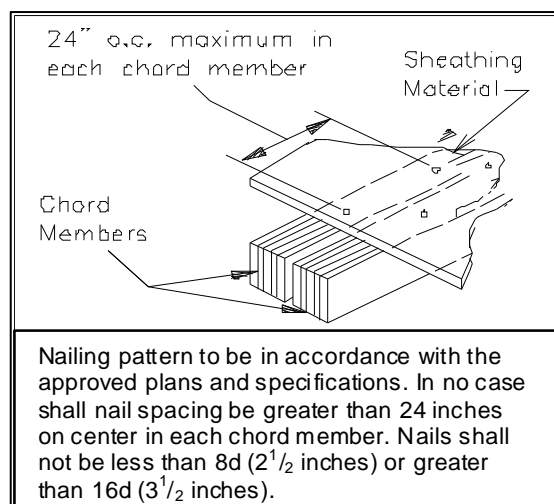

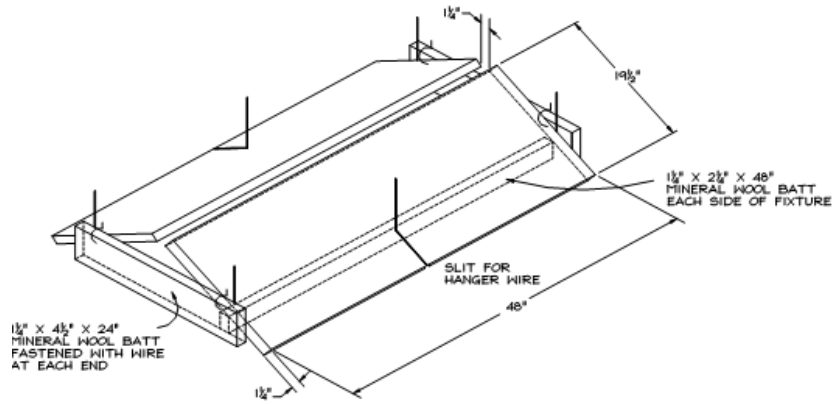

FIGURE 1—LIGHT FIXTURE PROTECTION
 (See Section 4.12.1 for detailed description of mineral wool batts.)
 For SI: 1 inch = 25.4 mm.

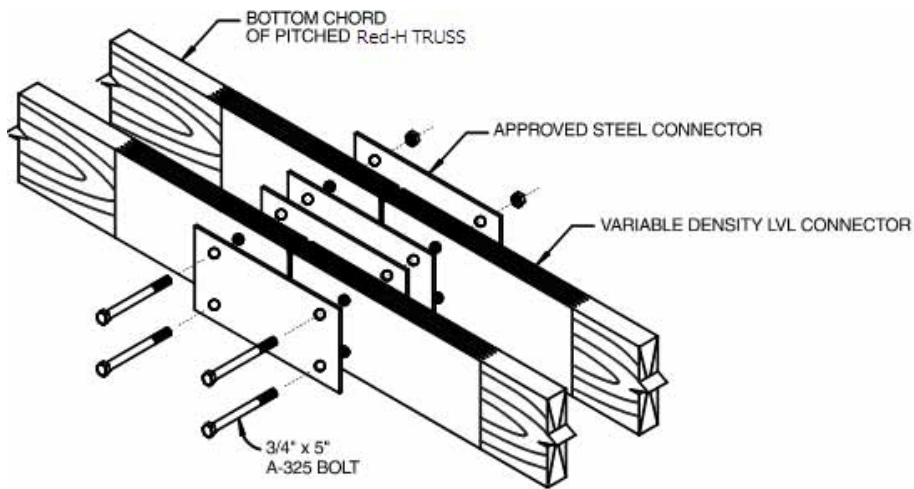
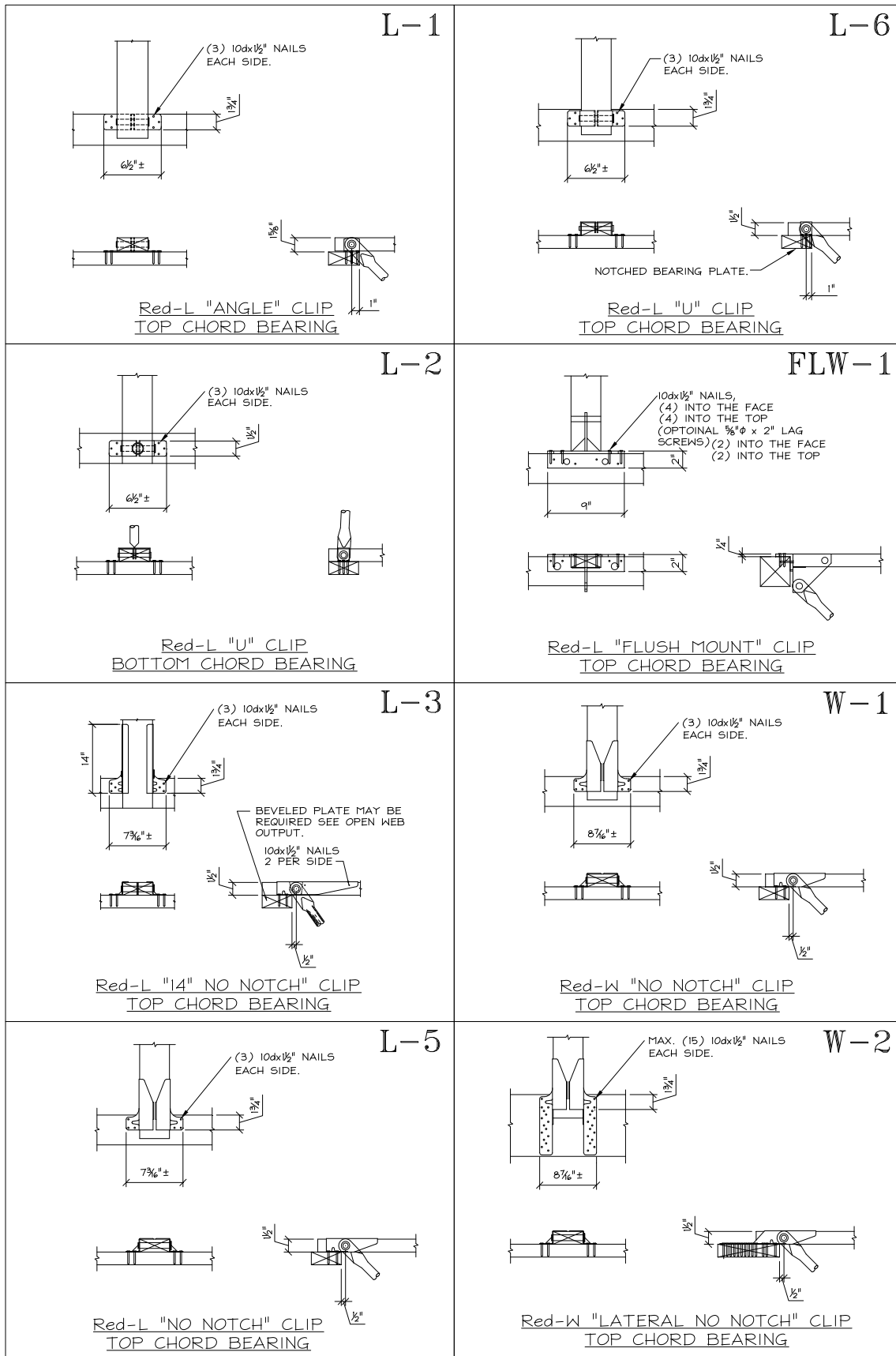
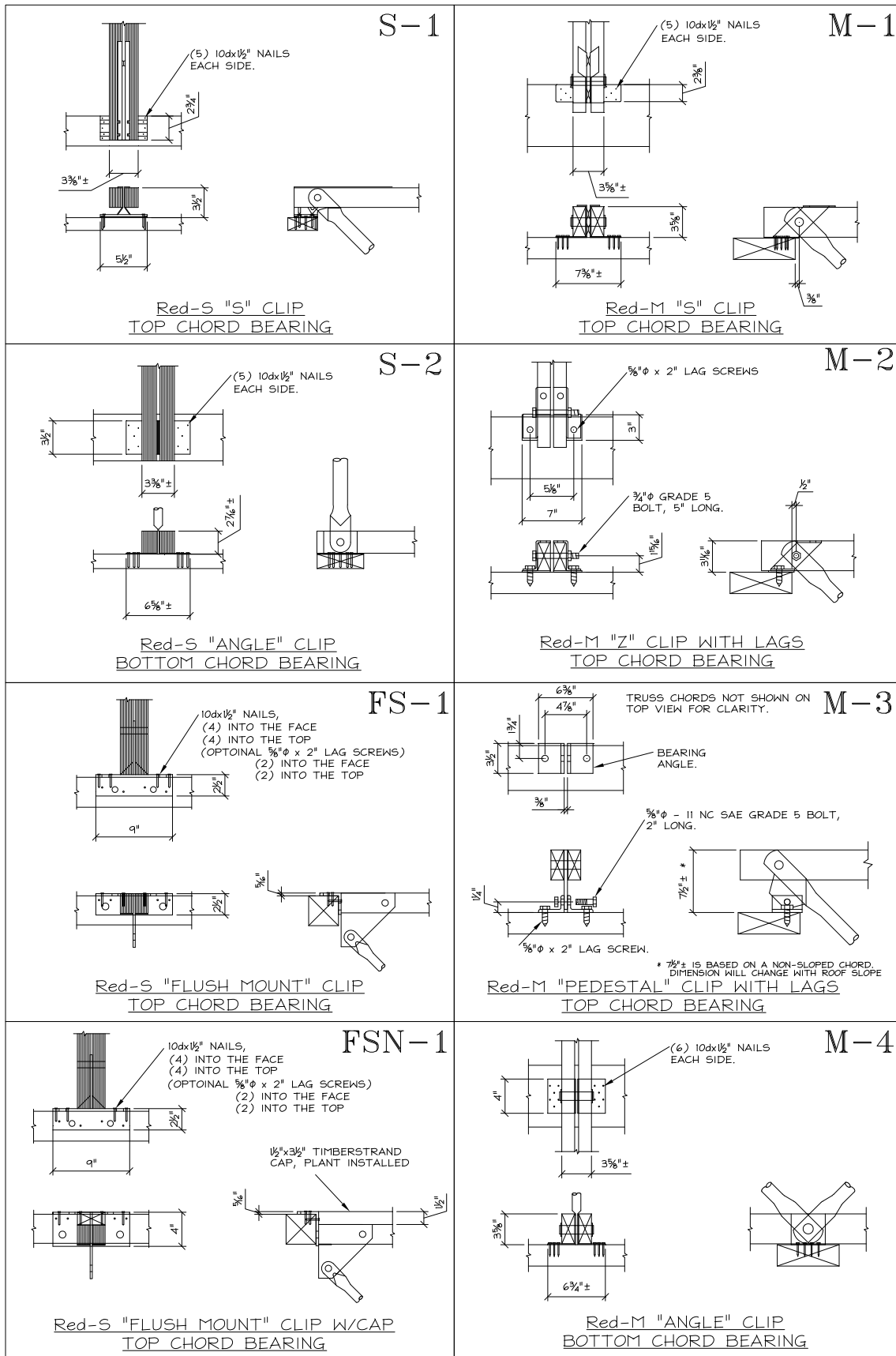

FIGURE 2—TENSION CONNECTOR (Red-H Connector shown for illustrative purposes only)
 For SI: 1 inch = 25.4 mm.



For SI: 1 inch = 25.4 mm.

FIGURE 3—OPEN-WEB TRUSS DETAILS (See note at end of Figure 3)



For SI: 1 inch = 25.4 mm.

FIGURE 3—OPEN-WEB TRUSS DETAILS (Continued) (See note at end of Figure 3)

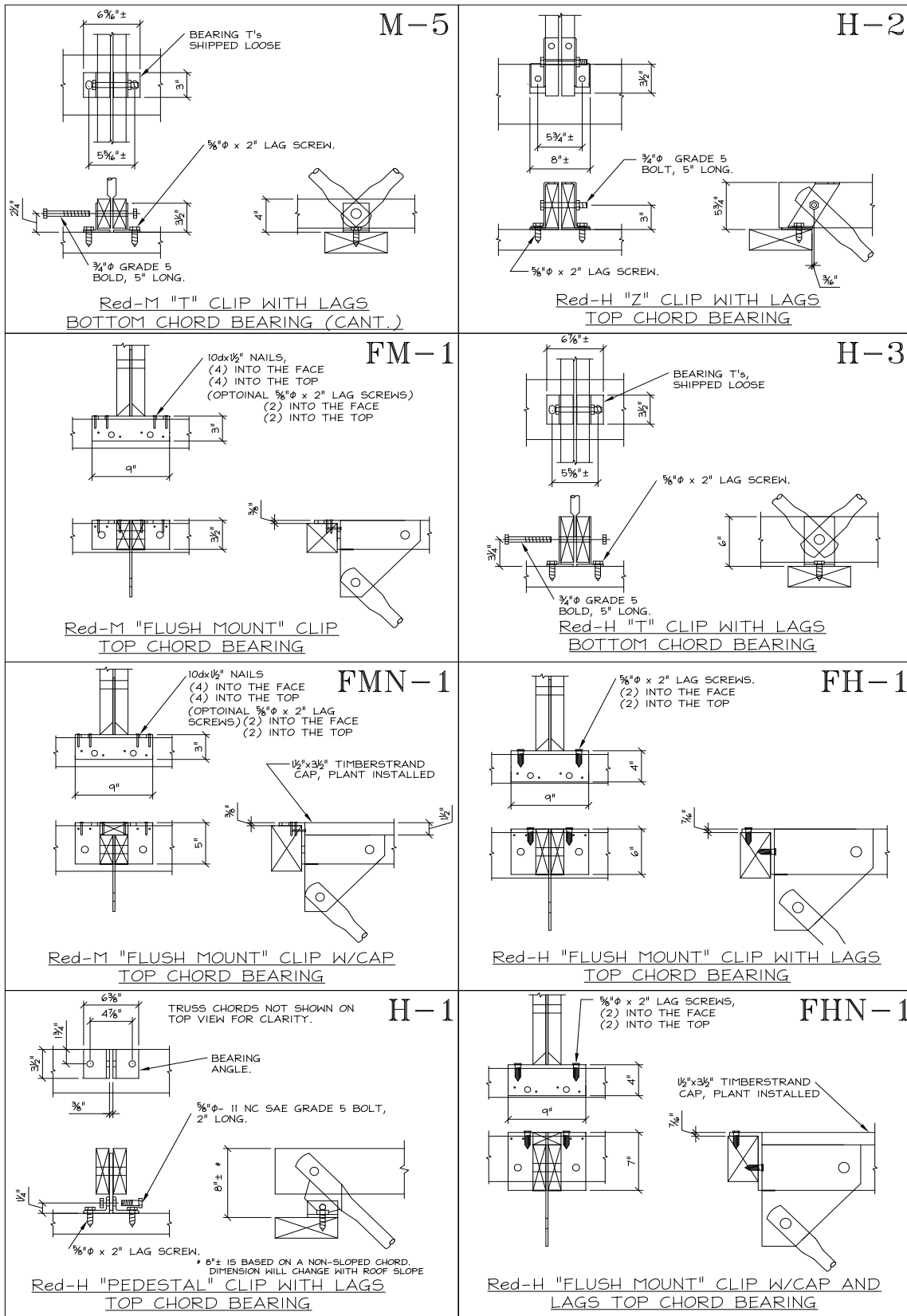

For SI: 1 inch = 25.4 mm.

FIGURE 3—OPEN-WEB TRUSS DETAILS (Continued) (See note below)

Note 1: Figure 3 drawings are for illustration purposes only. They are not intended for use as construction documents for the purpose of design, fabrication or erection.

Note 2: Structural performance of the bearing hardware is not dependent upon the nails used to connect the bearing hardware to the supporting structure. The connection may be considered, however, by the building designer in the design requirements of the structure.

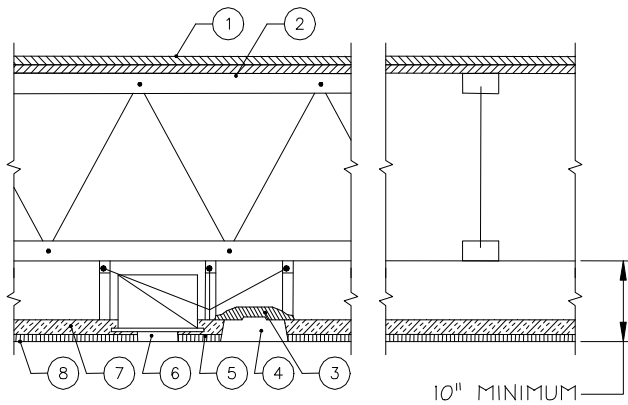

ASSEMBLY A (See Section 4.12.1 of this report.)

1. Double Wood Floor.
2. Open-Web Trusses
3. Fixture protection.
4. 24 inch x 48 inch recessed light fixture.
5. Cold-rolled channels.
6. 12 inch air diffuser.
7. Thermafiber, Fibrex-FBX, Fibrex-IF, or IIG MinWool mineral wool blankets.
8. 5/8-inch thick acoustical panels 24 inches x 24 inches or 24 inches x 48 inches supported by an approved exposed fire-rated suspension system.

ASSEMBLY B (See Section 4.12.2 of this report.)

1. 48/24 tongue-and-groove span rated sheathing (Exposure 1).
2. Two layers of 1/2-inch-thick Type X gypsum board.
3. Open-Web Trusses
4. Optional minimum 3 1/2-inch-thick glass fiber insulation rated R-30 or less, with resilient channels (not shown).

Sound Test Data*

	STC = 50	
W/O Gypsum Concrete	Pad & Carpet	IIC = 60
	Tarkett Acoustiflor	IIC = 51 (1)
	Cushioned vinyl	IIC = 45 (2)
	STC = 58	
W/Gypsum Concrete	Pad & Carpet	IIC = 54
	Tarkett Acoustiflor	IIC = 54 (1)
	Armstrong Vios/Armstrong	IIC = 50 (1)
	Cambray sheet vinyl	

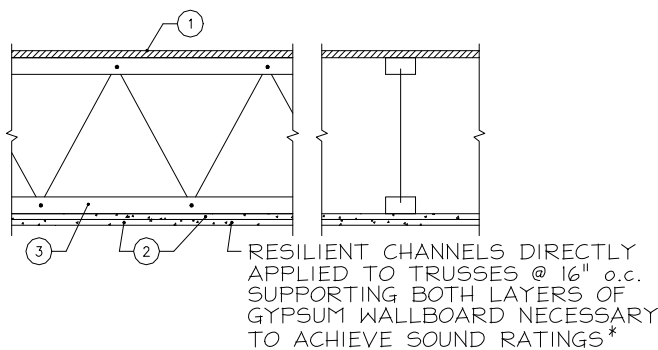

- (1) Requires two layers of 5/8-inch-thick Type X gypsum board with minimum 3 1/2-inch-thick glass fiber insulation rated R-30 or less.
- (2) Applicable only in jurisdictions using the IRC, BNBC or SBC.

ASSEMBLY C (See Section 4.12.3 of this report.)

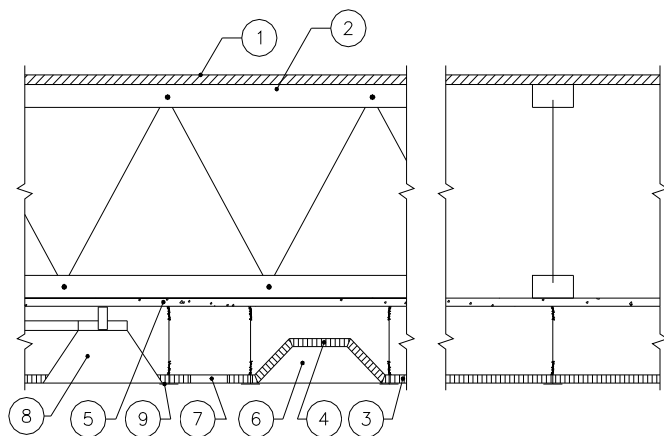

1. 48/24 tongue-and-groove span rated sheathing (Exposure 1).
2. Open-Web Trusses
3. 5/8-inch-thick x 24 inch x 24 inch ceiling panels.
4. Fixture protection.
5. 1/2-inch-thick Type X gypsum board.
6. 24 inch x 48 inch recessed light fixture.
7. 6 inch x 12 inch opening for return air.
8. 12-inch-diameter diffuser opening.
9. Fire-resistance rated steel suspension grid.

For SI: 1 inch = 25.4 mm.

FIGURE 4—ONE-HOUR FIRE-RESISTANCE-RATED ASSEMBLY DETAILS

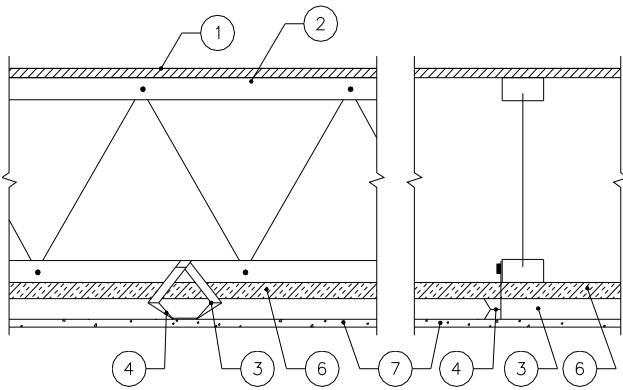

ASSEMBLY D (See Section 4.12.4 of this report.)

1. 48/24 tongue-and-groove span rated sheathing (Exposure 1).
2. Open-Web Trusses
3. No. 26 gauge galvanized steel furring channel installed perpendicular to joists or trusses. Furring channels spaced 1 1/2 inches from and on each side of wallboard end joints and 24 inches on center away from end joints. Channel secured to trusses with support clips (Item 4) at each truss location. At channel splices, adjacent pieces overlapped 6 inches and tied with double strand of No. 18 SWG galvanized steel wire at each end of overlap.
4. Simpson Strong-Tie Co. Type CSC support clips to be used to support furring channels at the intersection with each truss. Support clips nailed to side of truss bottom chord with 1 1/2-inch-long No. 11 gauge nail.
5. Stabilizer strap (not shown) - 3/4-inch x 6-inch No. 24 gauge galvanized steel strap used to prevent rotation of the support clips at wallboard end joints and along walls.
6. 1 inch thick, 6 pcf minimum, Thermafiber, Fibrex-FBX, Fibrex-IF, or IIG MinWool mineral wool blankets.
7. 1/2 inch thick USG Type C FIRECODE or ProRoc Type C gypsum board.

Sound Test Data:

W/Gypsum	STC = 59	
Concrete	Pad & Carpet	IIC = 54
Without Gypsum	STC = 47 (1)	
Concrete	Pad & Carpet	IIC = 54

(1) Applicable only in jurisdictions using the IRC, BNBC or SBC.

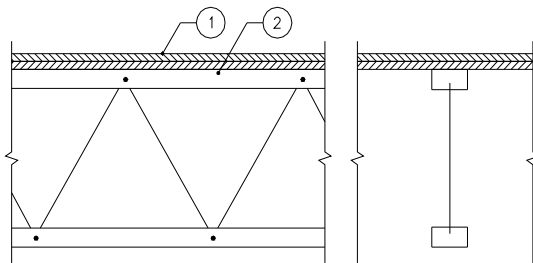

ASSEMBLY E (See Section 4.12.5 of this report.)

1. Double wood floor or a single layer of 48/24 span-rated tongue-and-groove sheathing (Exposure 1).
2. An approved ceiling system that will provide a 40-minute finish rating. An example of a ceiling with a 40-minute finish rating is described in Section 4.12.2 of this report.

ASSEMBLY F Not used.

For SI: 1 inch = 25.4 mm.

Alternate Floor or Roof Systems: Lightweight concrete or gypsum concrete may be added to Assemblies A, B, C, D and E of this report in accordance with Section 4.14.

FIGURE 4—ONE-HOUR FIRE-RESISTANCE-RATED ASSEMBLY DETAILS (Continued)

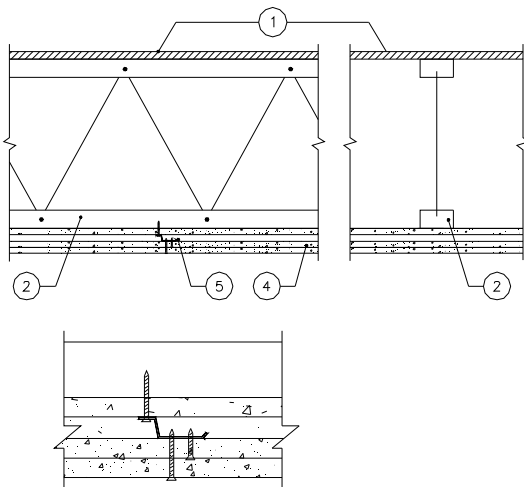

ASSEMBLY G (See Section 4.13 of this report.)

1. 48/24 tongue-and-groove span rated sheathing (Exposure 1).
2. Open-Web Trusses, 24 inches on center maximum.
3. Optional glass fiber insulation, unfaced batts, 3 1/2 inches thick in plenum, supported by stay wires 12 inches on center and centered on truss bottom chords.
4. Three layers of 5/8-inch-thick Gold Bond Fireshield G Type X gypsum board.
5. Resilient channels at 16 inches on center located between first and second layers of gypsum board. (See Section 4.13 of this report.)

(Insert shows typical resilient channel and gypsum board attachment.)

For SI: 1 inch = 25.4 mm.

Alternate Floor or Roof Systems: Lightweight concrete or gypsum concrete may be added to Assembly G of this report in accordance with Section 4.14.

FIGURE 5—TWO-HOUR FIRE-RESISTANCE-RATED FLOOR-CEILING OR ROOF-CEILING ASSEMBLY

Detail A:

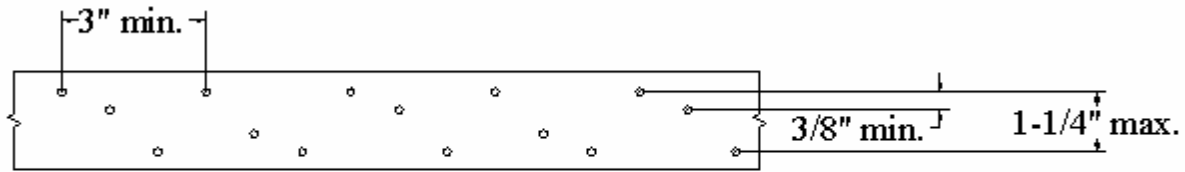

3 rows of 10d x 1.5" nails at 3" o.c.

Detail A is applicable to all Open-Web trusses with structural composite lumber chords, except when Red-S, Red-M and Red-H Open-Web trusses are used, a minimum 2 x 4 nominal structural composite lumber nailer plate is required. Nailer plate attachment must be designed to transfer the required forces. Simpson Strong-Tie Co. MSTI or PAI straps, or other straps of the same minimum gauge, dimensions, grade of steel and nail patterns and recognized in a current ICC-ES evaluation report or ICC-ES legacy report may be used.

Detail B:

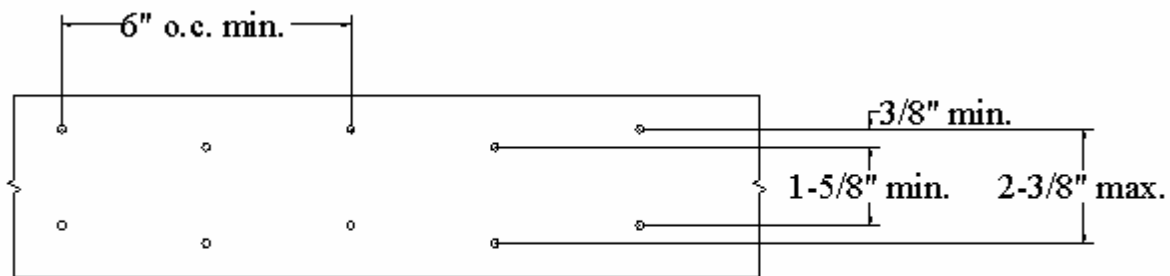

4 rows of 10d x 1.5" nails at 6" o.c.

Detail B is applicable to all Open-Web trusses with structural composite lumber chords. Simpson Strong-Tie Co. LSTI or LTTI straps, or other straps of the same minimum gauge, dimensions, grade of steel and nail patterns and recognized in a current ICC-ES evaluation report or ICC-ES legacy report may be used.

General Notes:

Connection capacity limited to a lateral nail design value of 112 lbs/nail with the following conditions.

1. All nails must be 10d short nails, 0.148 inches x 1.5 inches.
2. Minimum steel thickness is 18 gauge (0.049 inches).
3. Total connection capacity not to exceed code approved strap or tension-tie design value.
4. The connection capacity is permitted to be increased for duration of load in accordance with the code.
5. No additional reductions are necessary due to penetration.
6. The minimum required end distance is 3 inches.

For **SI**: 1 inch = 25.4 mm, 1 lbf. = 4.448 N.

FIGURE 6—METAL STRAP AND TENSION-TIE CONNECTION CAPACITIES AND DETAILS FOR OPEN-WEB TRUSSES



FIGURE 7—REDBUILT LOGO